

VTM-30-250

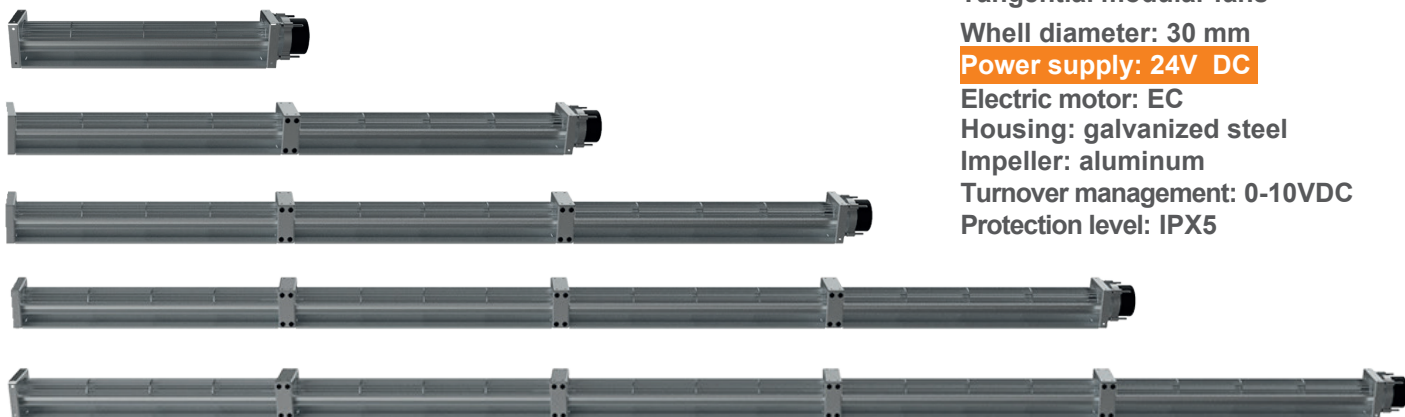

Tangential modular fans
Wheel diameter: 30 mm
Power supply: 24V DC
 Electric motor: EC
 Housing: galvanized steel
 Impeller: aluminum
 Turnover management: 0-10VDC
 Protection level: IPX5

| Type | Sections | Power input, W | Tok, A | Air flow, m3/h | Speed, min-1 | Noise level, dBa |
|---------------------|----------|----------------|--------|----------------|--------------|------------------|
| VTM-30-250-24DC-A-1 | 1 | 2,40 | 0,1 | 55 | 2000 | 17 |
| VTM-30-250-24DC-A-2 | 2 | 2,88 | 0,12 | 110 | 2000 | 19 |
| VTM-30-250-24DC-A-3 | 3 | 3,36 | 0,14 | 165 | 2000 | 21 |
| VTM-30-250-24DC-A-4 | 4 | 3,84 | 0,16 | 220 | 2000 | 23 |
| VTM-30-250-24DC-A-5 | 5 | 4,32 | 0,18 | 275 | 2000 | 25 |

VTM-30-250

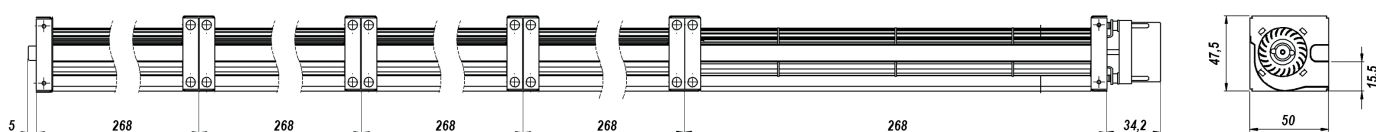

VTM-30-300

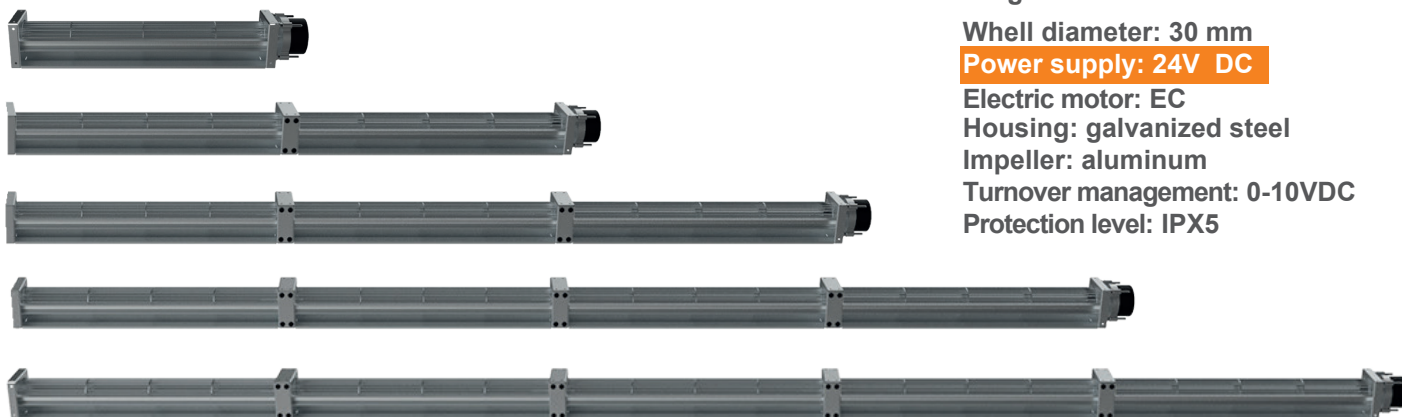

Tangential modular fans

Wheel diameter: 30 mm

Power supply: 24V DC

Electric motor: EC

Housing: galvanized steel

Impeller: aluminum

Turnover management: 0-10VDC

Protection level: IPX5

| Type | Sections | Power input, W | Tox, A | Air flow, m3/h | Speed, min-1 | Noise level, dBa |
|---------------------|----------|----------------|--------|----------------|--------------|------------------|
| VTM-30-300-24DC-A-1 | 1 | 2,28 | 0,12 | 60 | 2000 | 18 |
| VTM-30-300-24DC-A-2 | 2 | 3,36 | 0,14 | 120 | 2000 | 20 |
| VTM-30-300-24DC-A-3 | 3 | 3,84 | 0,16 | 180 | 2000 | 22 |
| VTM-30-300-24DC-A-3 | 4 | 4,32 | 0,18 | 240 | 2000 | 24 |
| VTM-30-300-24DC-A-3 | 5 | 4,56 | 0,19 | 300 | 2000 | 26 |

VTM-30-300

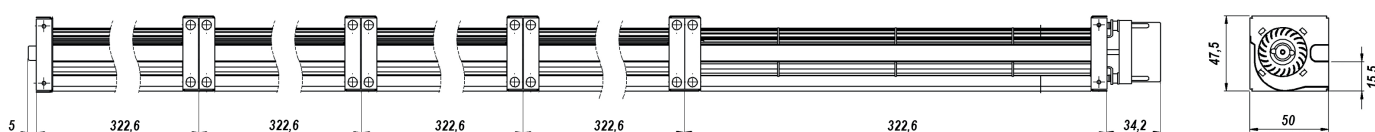

VTM-30-350

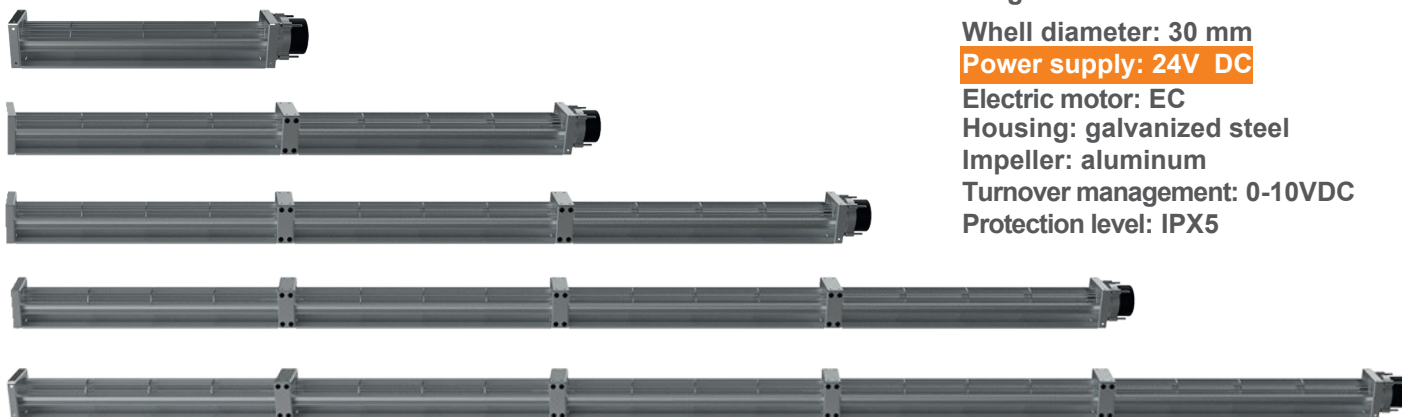

Tangential modular fans

Wheel diameter: 30 mm

Power supply: 24V DC

Electric motor: EC

Housing: galvanized steel

Impeller: aluminum

Turnover management: 0-10VDC

Protection level: IPX5

| Type | Sections | Power input, W | T _{0x} , A | Air flow, m ³ /h | Speed, min ⁻¹ | Noise level, dBa |
|---------------------|----------|----------------|---------------------|-----------------------------|--------------------------|------------------|
| VTM-30-350-24DC-A-1 | 1 | 1,92 | 0,12 | 65 | 2000 | 19 |
| VTM-30-350-24DC-A-2 | 2 | 2,16 | 0,14 | 130 | 2000 | 21 |
| VTM-30-350-24DC-A-3 | 3 | 3,12 | 0,16 | 195 | 2000 | 23 |
| VTM-30-350-24DC-A-3 | 4 | 3,84 | 0,18 | 260 | 2000 | 25 |
| VTM-30-350-24DC-A-3 | 5 | 4,08 | 0,2 | 325 | 2000 | 27 |

VTM-30-350

